

ЦЕНТРАЛИЗОВАННАЯ СИСТЕМА СМАЗКИ С30F



Архангельск (8182)63-90-72
Астана (7172)727-132
Астрахань (8512)99-46-04
Барнаул (3852)73-04-60
Белгород (4722)40-23-64
Брянск (4832)59-03-52
Владивосток (423)249-28-31
Волгоград (844)278-03-48
Вологда (8172)26-41-59
Воронеж (473)204-51-73
Екатеринбург (343)384-55-89
Иваново (4932)77-34-06

Ижевск (3412)26-03-58
Иркутск (395)279-98-46
Казань (843)206-01-48
Калининград (4012)72-03-81
Калуга (4842)92-23-67
Кемерово (3842)65-04-62
Киров (8332)68-02-04
Краснодар (861)203-40-90
Красноярск (391)204-63-61
Курск (4712)77-13-04
Липецк (4742)52-20-81

Киргизия (996)312-96-26-47

Магнитогорск (3519)55-03-13
Москва (495)268-04-70
Мурманск (8152)59-64-93
Набережные Челны (8552)20-53-41
Нижний Новгород (831)429-08-12
Новокузнецк (3843)20-46-81
Новосибирск (383)227-86-73
Омск (3812)21-46-40
Орел (4862)44-53-42
Оренбург (3532)37-68-04
Пенза (8412)22-31-16

Россия (495)268-04-70

Пермь (342)205-81-47
Ростов-на-Дону (863)308-18-15
Рязань (4912)46-61-64
Самара (846)206-03-16
Санкт-Петербург (812)309-46-40
Саратов (845)249-38-78
Севастополь (8692)22-31-93
Симферополь (3652)67-13-56
Смоленск (4812)29-41-54
Сочи (862)225-72-31
Ставрополь (8652)20-65-13

Казахстан (772)734-952-31

Сургут (3462)77-98-35
Тверь (4822)63-31-35
Томск (3822)98-41-53
Тула (4872)74-02-29
Тюмень (3452)66-21-18
Ульяновск (8422)24-23-59
Уфа (347)229-48-12
Хабаровск (4212)92-98-04
Челябинск (351)202-03-61
Череповец (8202)49-02-64
Ярославль (4852)69-52-93

SERIES C30F AIR-OPERATED PUMP

10 Litres

DRUM

Depending on available feed type, on system's specifics or on required dispense, an air-operated pump may be preferred to an electric one.

Various solutions are available for great versatility: with 10 liters tank or suitable for 20, 50 or 200 Kg drums, provided with drum cover and grease follower plate (if necessary).

If commercial drums are used, once the lubricant is finished the end user can replace the drum or fill it up again through the specific inlet, on request with a special kit. Oil pumps are provided with drum cover for open drums (up to 50 kg) or with ring nut for closed drums (usually from 50 kg to 200 kg). High compression ratio (50:1) and adjustable feeding pressure allow to set system's pressure to its specific requirements (from 100 to 350 bar).



TECHNICAL CHARACTERISTICS

Max flow rate	*	1330 cm ³ /min
Max working pressure		8 bar
Pressure ratio		50:1
Air inlet connection		F 1/4" G
Lubricant outlet connection		F 3/8" G
Operating temperature		- 25 °C / + 60 °C
Lubricant		Oil > 40 cSt - Grease max NLGI 2

* Approx. delivery with grease NLGI 2 at 18°C.

PUMP OUTLET ASSEMBLY

This group includes:

- **Manometer:** checks system's pressure.
- **Overpressure valve:** allows to monitor system's pressure and discharges lubricant when system is over pressurized 100 - 350 bar.
- **Inlet charging filter:** to filter the lubricant during drum's filling.
- **Bleeding valve:** discharges system's residual air during first filling operations.

Inlet charging filter 300 µm

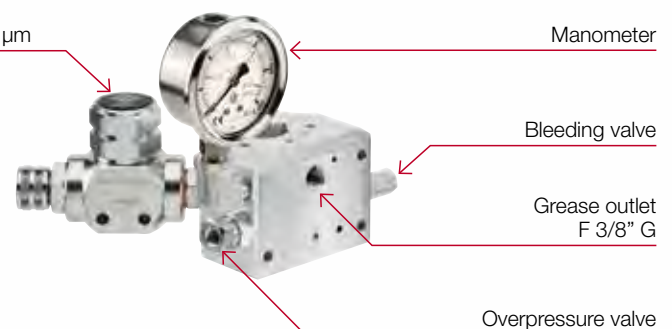

Manometer

Bleeding valve

Grease outlet
F 3/8" G

Overpressure valve

GUIDE TO CHOOSING GREASE PUMP

P/N Grease	Tank capacity	Drum internal ø (mm)	Pump (R 50:1)	Drum cover	Follower plate	Pump outlet assembly
3085005	10 litres	220	62741	-	10/617	-
3085275	20 Kg	255/300	62148	10/537	66310	3081710
3085545	50 Kg	335/360	62174	10/533	66370	3081710
3085680	60 Kg	360/400	62174	10/532	66400	3081710
3085815	200 Kg	540/580	62195	10/531	66590	3081710

GUIDE TO CHOOSING OIL PUMP

P/N Oil	Tank capacity	Drum external ø (mm)	Pump (R 50:1)	Drum cover	Drum ring	Pump outlet assembly
3085950	10 litres	240	62741	-	-	-
3086220	20 Kg	260/330	62148	10/537	-	3081710
3086490	50 - 60 Kg	340/385	62174	10/533	-	3081710
3086625	50 - 60 Kg	closed - thread 2"	62174	level 39650	38041	3081710
3086760	200 Kg	closed - thread 2"	62195	level 39650	38041	3081710

STANDARD EQUIPMENT

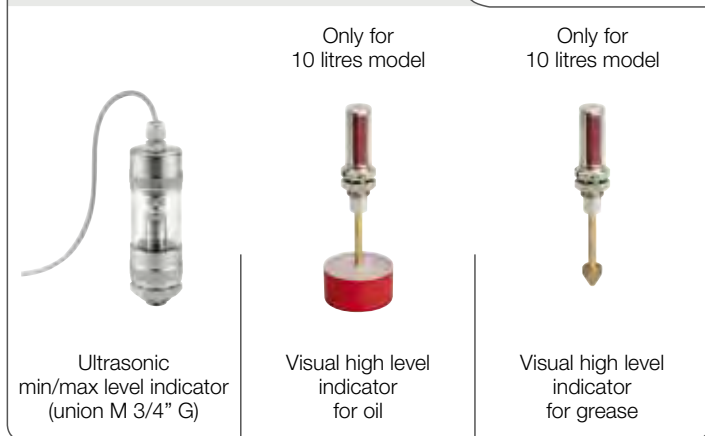

ON REQUEST



OVERALL DIMENSIONS (mm)

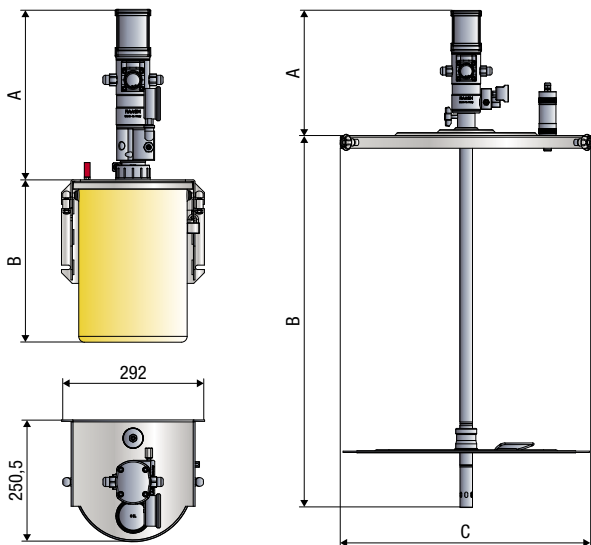

P/N Grease	A	B	C
3085005	351	335	292
3085275	355	361	341
3085545	355	621	389
3085680	355	621	424
3085815	355	835	604

P/N Oil	A	B	C
3085950	351	335	292
3086220	355	361	341
3086490	355	621	389
3086625	355	621	424
3086760	355	835	604

	10 litres		20 Kg		50 Kg		60 Kg		220 Kg	
	Grease	Oil	Grease	Oil	Grease	Oil	Grease	Oil	Grease	Oil
Packing-m ³	1-0,056	1-0,056	2-0,087	2-0,087	2-0,076	2-0,076	2-0,076	2-0,036	2-0,100	2-0,040
Net weight Kg	16,5	15,5	9,6	8,7	10,7	9,1	11,2	6,9	16,3	7,6
Gross weight Kg	16,8	15,8	10,2	9,3	11,3	9,7	11,8	7,5	17,1	8,4

Type of lubrication system with

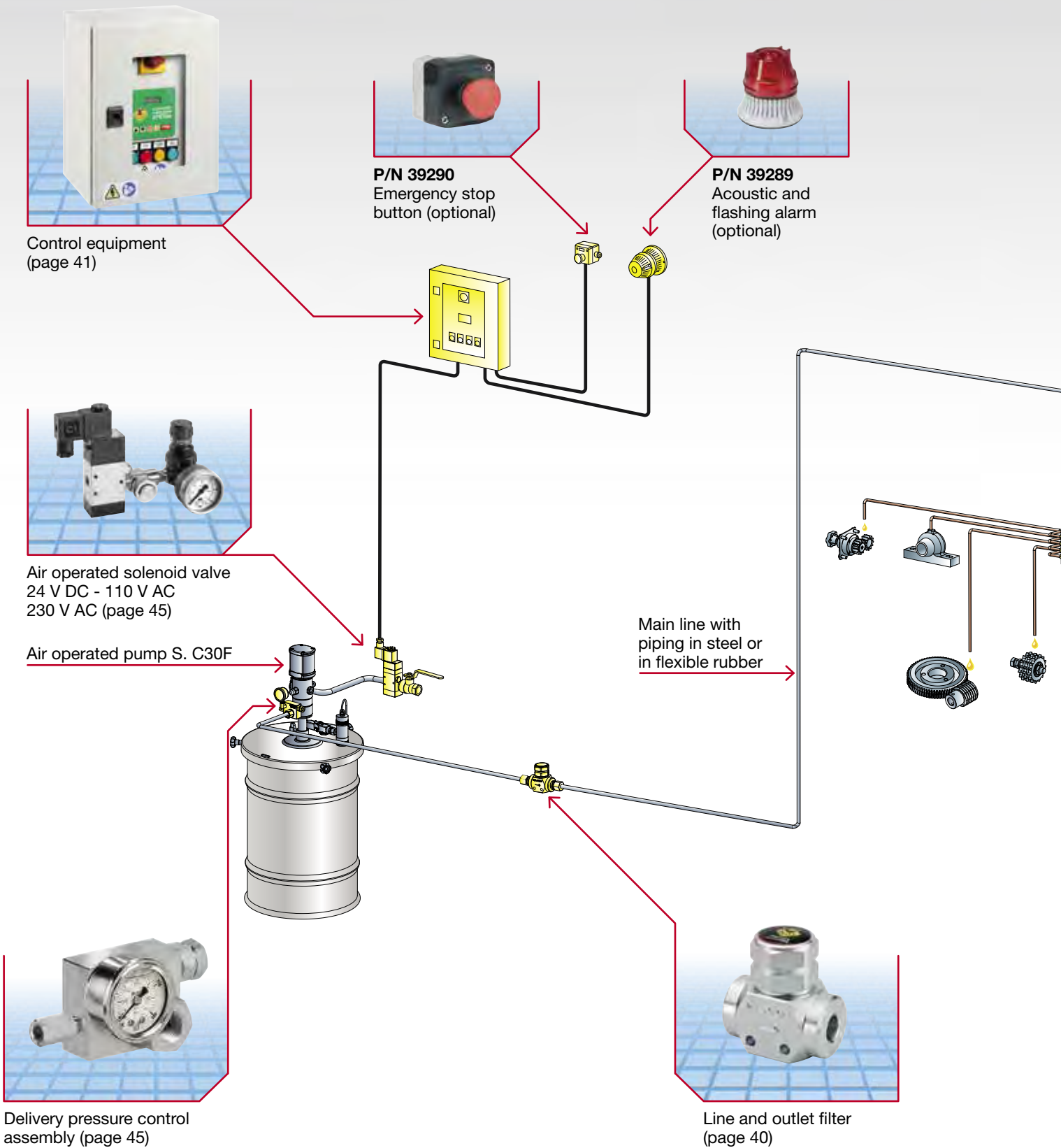

AIR-OPERATED PUMP C30F



Monobloc and modular
"Master" divider valves
MDV-M and MDV-L
(page 30-36)



Cycle indicator (page 34)

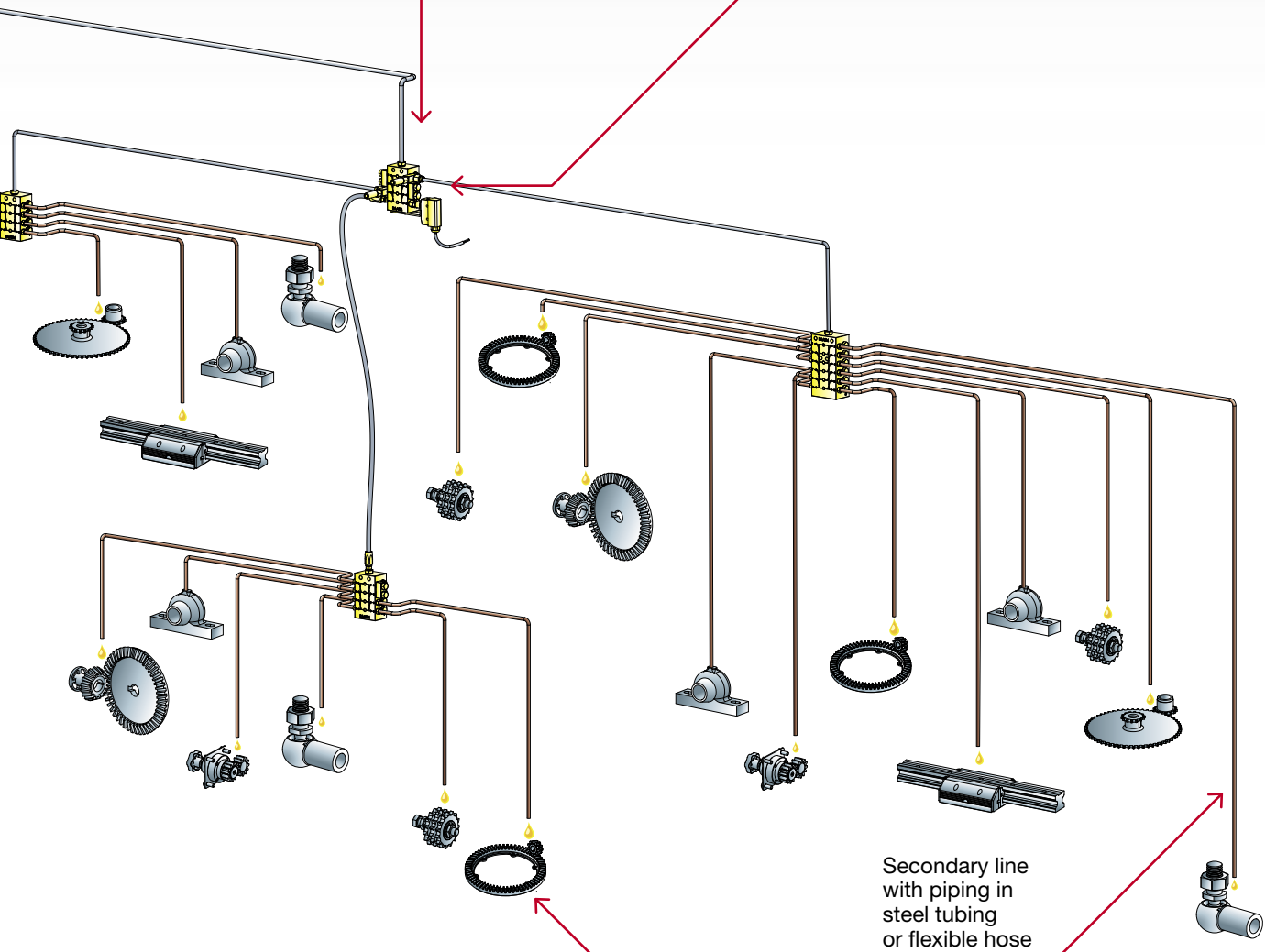

Lube point: In the plant are represented some types of moving parts that need to be lubricated



Архангельск (8182)63-90-72
Астана (7172)727-132
Астрахань (8512)99-46-04
Барнаул (3852)73-04-60
Белгород (4722)40-23-64
Брянск (4832)59-03-52
Владивосток (423)249-28-31
Волгоград (844)278-03-48
Вологда (8172)26-41-59
Воронеж (473)204-51-73
Екатеринбург (343)384-55-89
Иваново (4932)77-34-06

Ижевск (3412)26-03-58
Иркутск (395)279-98-46
Казань (843)206-01-48
Калининград (4012)72-03-81
Калуга (4842)92-23-67
Кемерово (3842)65-04-62
Киров (8332)68-02-04
Краснодар (861)203-40-90
Красноярск (391)204-63-61
Курск (4712)77-13-04
Липецк (4742)52-20-81

Киргизия (996)312-96-26-47

Магнитогорск (3519)55-03-13
Москва (495)268-04-70
Мурманск (8152)59-64-93
Набережные Челны (8552)20-53-41
Нижний Новгород (831)429-08-12
Новокузнецк (3843)20-46-81
Новосибирск (383)227-86-73
Омск (3812)21-46-40
Орел (4862)44-53-42
Оренбург (3532)37-68-04
Пенза (8412)22-31-16

Россия (495)268-04-70

Пермь (342)205-81-47
Ростов-на-Дону (863)308-18-15
Рязань (4912)46-61-64
Самара (846)206-03-16
Санкт-Петербург (812)309-46-40
Саратов (845)249-38-78
Севастополь (8692)22-31-93
Симферополь (3652)67-13-56
Смоленск (4812)29-41-54
Сочи (862)225-72-31
Ставрополь (8652)20-65-13

Казахстан (772)734-952-31

Сургут (3462)77-98-35
Тверь (4822)63-31-35
Томск (3822)98-41-53
Тула (4872)74-02-29
Тюмень (3452)66-21-18
Ульяновск (8422)24-23-59
Уфа (347)229-48-12
Хабаровск (4212)92-98-04
Челябинск (351)202-03-61
Череповец (8202)49-02-64
Ярославль (4852)69-52-93

<https://raasm.nt-rt.ru> || rmf@nt-rt.ru